

इंटरनेट

मानक

Disclosure to Promote the Right To Information

Whereas the Parliament of India has set out to provide a practical regime of right to information for citizens to secure access to information under the control of public authorities, in order to promote transparency and accountability in the working of every public authority, and whereas the attached publication of the Bureau of Indian Standards is of particular interest to the public, particularly disadvantaged communities and those engaged in the pursuit of education and knowledge, the attached public safety standard is made available to promote the timely dissemination of this information in an accurate manner to the public.

“जानने का अधिकार, जीने का अधिकार”

Mazdoor Kisan Shakti Sangathan

“The Right to Information, The Right to Live”

“पुराने को छोड़ नये के तरफ”

Jawaharlal Nehru

“Step Out From the Old to the New”

IS 15589 (2005): Textiles fabrics - Burning behaviour - Determination of ease of ignition of vertically oriented specimens [TXD 32: Textiles Protective Clothing]



“ज्ञान से एक नये भारत का निर्माण”

Satyanarayan Gangaram Pitroda

“Invent a New India Using Knowledge”



“ज्ञान एक ऐसा खजाना है जो कभी चुराया नहीं जा सकता है”

Bhartrhari—Nitiśatakam

“Knowledge is such a treasure which cannot be stolen”

BLANK PAGE



भारतीय मानक
वस्त्रादि — ज्वलन व्यवहार — टंगे नमूनों की
ज्वलनशीलता ज्ञात करना

Indian Standard

TEXTILE FABRICS — BURNING BEHAVIOUR —
DETERMINATION OF EASE OF IGNITION OF
VERTICALLY ORIENTED SPECIMENS

ICS 13.220.40;59.080.30

© BIS 2005

BUREAU OF INDIAN STANDARDS
MANAK BHAVAN, 9 BAHADUR SHAH ZAFAR MARG
NEW DELHI 110002

NATIONAL FOREWORD

This Indian Standard which is identical with ISO 6940 : 2004 'Textile fabrics — Burning behaviour — Determination of ease of ignition of vertically oriented specimens' issued by the International Organization for Standardization (ISO) was adopted by the Bureau of Indian Standards on the recommendations of the Chemical Methods of Test Sectional Committee (TX 05) and approval of the Textile Division Council.

This standard specifies conditioning temperature of $20\pm 2^{\circ}\text{C}$. The National Annex A specifies conditioning temperature as $27\pm 2^{\circ}\text{C}$ suitable for the tropical countries like India.

The other related Indian Standard for the burning behaviour of textile fabrics is as under:

IS 15590 : 2005 Textile fabrics — Burning behaviour — Measurement of flame spread properties of vertically oriented specimens

The text of ISO Standard has been approved as suitable for publication as an Indian Standard with the above deviation. Certain conventions are, however, not identical to those used in Indian Standards. Attention is particularly drawn to the following:

- a) Wherever the words 'International Standard' appear referring to this standard, they should be read as 'Indian Standard'.
- b) Comma (,) has been used as a decimal marker while in Indian Standards, the current practice is to use a point (.) as the decimal marker.

In this adopted standard reference appears to the following International Standard for which Indian Standard also exists. The corresponding Indian Standard which is to be substituted in its place, is listed below along with its degree of equivalence for the edition indicated. However, the International Standard cross-referred in this adopted ISO Standard, which has subsequently been revised, position in respect of the latest ISO Standard has been given:

<i>International Standard</i>	<i>Corresponding Indian Standard</i>	<i>Degree of Equivalence</i>
ISO 4880 : 1997 Burning behaviour of textiles and textile products — Vocabulary	SP 45 : 1988 Handbook on glossary of textile terms	Technically equivalent

In reporting the results of a test or analysis made in accordance with this standard, if the final value, observed or calculated, is to be rounded off, it shall be done in accordance with IS 2 : 1960 'Rules for rounding off numerical values (*revised*)'.

Indian Standard

TEXTILE FABRICS — BURNING BEHAVIOUR — DETERMINATION OF EASE OF IGNITION OF VERTICALLY ORIENTED SPECIMENS

1 Scope

This International Standard specifies a method for the measurement of ease of ignition of vertically oriented textile fabrics and industrial products in the form of single or multi-component fabrics (coated, quilted, multilayered, sandwich constructions, and similar combinations), when subjected to a small, defined flame.

This method assesses the properties of textile fabrics in response to flame contact under controlled conditions. Results may not apply to situations where there is restricted air supply or exposure to large sources of intense heat.

The influence of seams on the behaviour of fabrics can be determined by this method, the seam being positioned within the test specimen so as to be subjected to the test flame. Whenever practicable, trimmings should be tested as part of the fabric assembly on which they are, or will be, used.

2 Normative references

The following referenced documents are indispensable for the application of this document. For dated references, only the edition cited applies. For undated references, the latest edition of the referenced document (including any amendments) applies.

ISO 4880, *Burning behaviour of textiles and textile products — Vocabulary*

ISO 6941, *Textile fabrics — Burning behaviour — Measurement of flame spread properties of vertically oriented specimens*

3 Terms and definitions

For the purposes of this document, the following terms and definitions apply.

3.1

flame application time

time for which the ignition flame is applied to the test specimen

3.2

afterflame time

duration of flame

length of time for which a material continues to flame under specified test conditions, after the ignition source has been removed

NOTE Afterflame time is measured to the nearest second and afterflame times of less than 1,0 s should be recorded as zero.

3.3

ignition

initiation of combustion

3.4

sustained combustion

flaming of the specimen which gives an afterflame time of 5 s or more or which reaches the top or vertical edges in less than 5 s

3.5

minimum ignition time

minimum time of exposure of a material to an ignition source to obtain sustained combustion under specified test conditions

4 Principle

A defined flame from a specified burner is applied to the surface or bottom edge of textile specimens which are vertically oriented.

The mean ignition time is determined as the weighted mean of the measured flame application times to obtain ignition of the specimens.

5 Apparatus

5.1 Mounting frame, constructed to a design capable of holding the gas burner (5.2, see Figure 1) and the test specimen holder (5.3, see Figure 2) in the specified relative orientation (see Figure 3).

5.2 Gas burner, as described in Annex A, capable of being moved from a standby position, where the tip of the burner is at least 75 mm from the test specimen, to either the horizontal or inclined operating position (see Figure 3).

5.3 Specimen holder, consisting of a rectangular metal frame having a specimen support pin at each corner of a rectangle of length 190 mm by width 70 mm (see Figure 2). The pins for supporting the specimen have a maximum diameter of 2 mm and a length of at least 26 mm.

NOTE Longer pins may be needed for mounting thick or multilayer specimens.

For the purpose of locating the specimen in a plane at least 20 mm away from the frame (see 9.1.1 and 9.2.1), a spacer stub of 2 mm diameter and a length of at least 20 mm shall be positioned adjacent to each of the four pins.

5.4 Template, flat and rigid, made of a suitable material and a size corresponding to the size of the specimen (200 mm × 80 mm). Holes approximately 4 mm in diameter are drilled in each corner of the template and positioned so that the distances between the centres of the holes correspond to the distances between the pins on the specimen holder (see Figure 2). The holes should be located equidistant about the vertical centreline of the template.

5.5 Gas, commercial grade propane or butane or butane/propane mixtures.

NOTE Commercial grade propane is preferred but other gases may be used.

5.6 Timing devices

5.6.1 A timing device to control and measure the flame application time, which can be set at 1 s and adjusted at 1 s intervals to an accuracy of 0,2 s or better.

5.6.2 Three timing devices reading to 0,2 s or better are required to measure the afterflame time. This device is started, preferably automatically, at the instant of test flame termination or removal, and is stopped manually.

6 Cautionary measures

6.1 Construction of testing equipment

Some products of combustion are corrosive. The equipment shall be constructed of material that will not be adversely affected by the fumes.

6.2 Location of test apparatus

The volume of air surrounding the test location shall not have any influence on testing. Where an open-fronted cabinet is used for the test, provision shall be made to allow the specimen to be mounted at least 300 mm from any wall.

6.3 Health and safety of test operators

Burning of materials may produce smoke and toxic gases that can affect the health of operators. Between tests, the atmosphere of the testing location, which shall be of adequate dimensions to avoid endangering the health of operators, shall be cleared of smoke and fumes by an extractor fan or other means of ventilation (see 6.2).

NOTE Smoke and fume emission may be subject to national regulations concerning atmospheric pollution control.

7 Sampling

7.1 Number of specimens

Mark out a set of twelve test specimens, using the template (5.4), to allow for at least five instances of ignition and five instances of non-ignition to occur.

Specimens should normally be tested with the length direction vertical and the outer face towards the igniting flame. If the test material is non-homogeneous and preliminary testing indicates dissimilar inflammability characteristics, length and width specimens should be tested separately. For surface ignition, where the two surfaces of the sample are visually dissimilar and preliminary testing indicates dissimilar inflammability characteristics, each surface shall be tested and the results reported separately.

An iterative procedure is used and the exact number of specimens cannot be stated. A minimum of 10 specimens is needed for each orientation. An extra test specimen is required for the setting-up procedure (see 9.1 and 9.2).

7.2 Specimen holder pin location marks

Mark the position through which the pins on the specimen holder must pass by means of the holes in the template (5.4).

NOTE Where the fabric is of open construction (e.g., scrim, gauze), small pieces of adhesive tape may be affixed to the fabric at the pin sites and the position marked on the tape.

7.3 Test specimen size

Cut out specimens $(200 \text{ mm} \pm 2 \text{ mm}) \times (80 \text{ mm} \pm 2 \text{ mm})$.

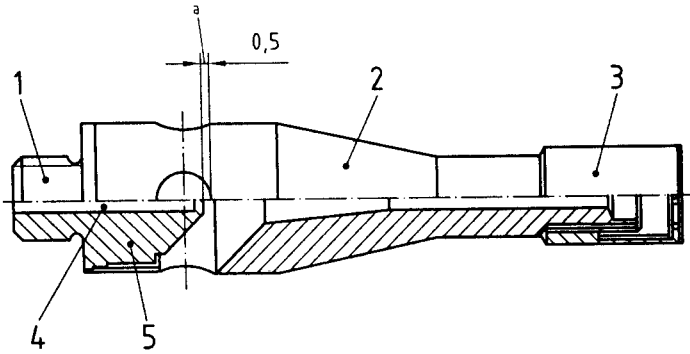

a) Gas burner arrangement

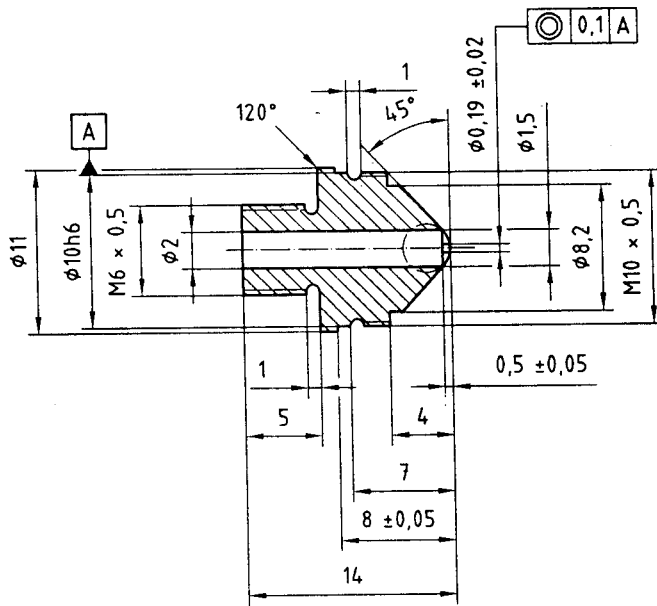

b) Gas jet

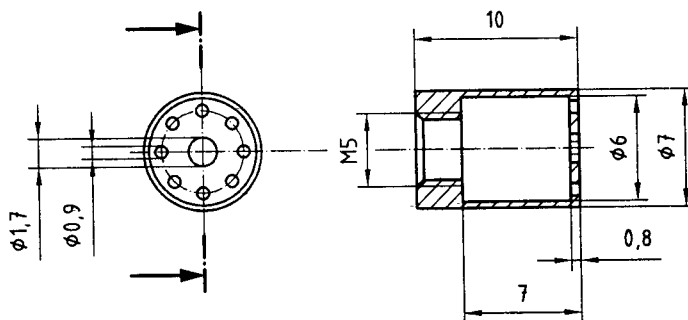

c) Flame stabilizer

Figure 1 — Gas burner

Dimensions in millimetres

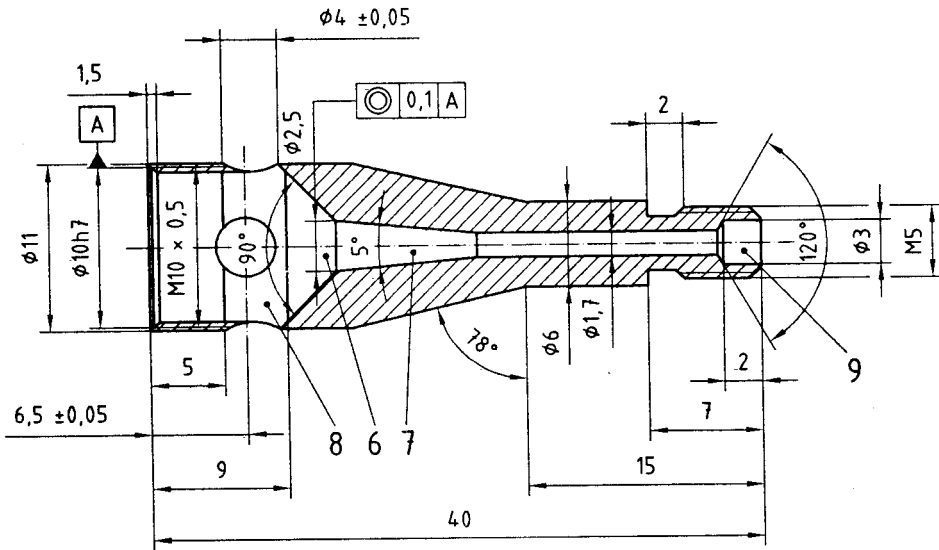

d) Burner tube

Key

- 1 gas jet
- 2 burner tube
- 3 flame stabilizer
- 4 choke tube
- 5 notch
- 6 gas mixing zone
- 7 diffusion zone
- 8 air chamber
- 9 outlet

^a Fitted during assembly

Figure 1 — Gas burner (continued)

8 Conditioning and testing atmosphere

8.1 Conditioning

Unless otherwise specified, test specimens shall be conditioned in an atmosphere having a temperature of $20\text{ }^{\circ}\text{C} \pm 2\text{ }^{\circ}\text{C}$ and a relative humidity of $65\% \pm 5\%$ for at least 24 h. If testing is not carried out immediately after conditioning, place the conditioned test specimens in a sealed container. Testing of each specimen shall begin within 2 min of removing it from either the conditioning atmosphere or the sealed container.

NOTE Care must be taken to avoid injury when mounting the specimens on the pins in the time specified. If necessary, the specimen may be mounted on the specimen holder (5.3) before removal from the conditioning atmosphere.

Dimensions in millimetres

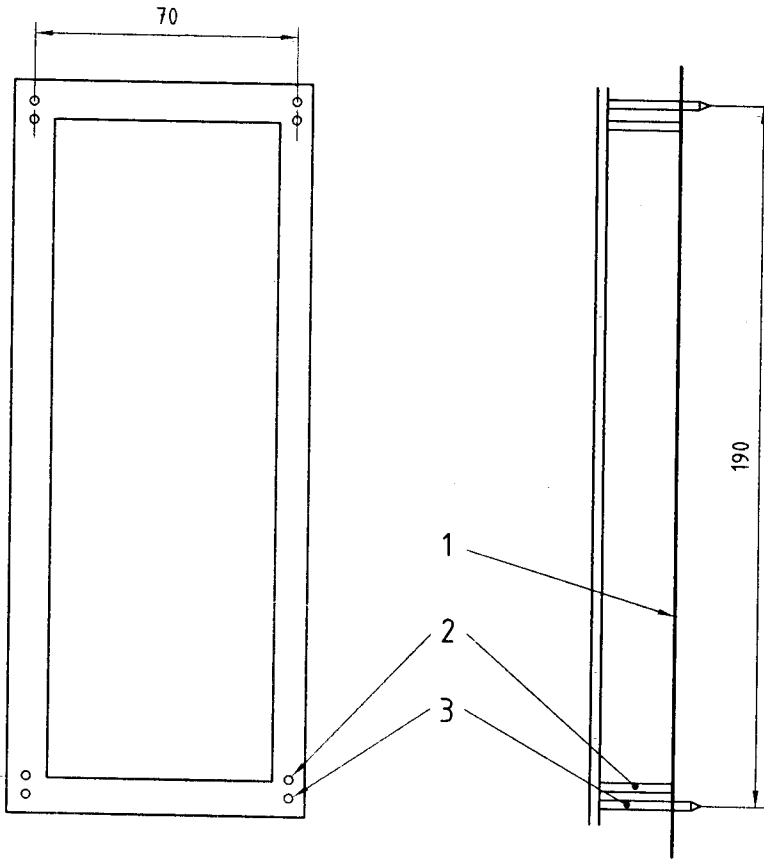

Key

- 1 test specimen
- 2 spacer stub
- 3 mounting pin

Figure 2 — Test specimen holder

8.2 Testing atmosphere

The tests should be performed in an atmosphere having a temperature between 10 °C and 30 °C, a relative humidity of between 15 % and 80 %, and air movement less than 0,2 m/s at the commencement of the test of each specimen. Air movement shall be measured at the flame application position and shall not be influenced by mechanical devices operating during the test.

NOTE Draught shields may be required to maintain stability of the test flame.

9 Setting up the apparatus

9.1 Procedure A (surface ignition)

9.1.1 Mounting the specimen

Place the test specimen (see 7.1) on the pins of the test specimen holder, making certain that the pins pass through the points marked off from the template and that the back of the specimen is at least 20 mm away from the rectangular metal frame of the test specimen holder. Fit the test specimen holder to the mounting frame with the specimen vertical.

9.1.2 Operating position of the burner

Position the burner perpendicular to the surface of the test specimen such that the axis of the burner is 20 mm above the line of the lower pins and is aligned with the vertical centreline of the face of the test specimen. Ensure that the tip of the burner stabilizer is $17 \text{ mm} \pm 1 \text{ mm}$ from the surface of the test specimen [see Figure 3 a)].

9.1.3 Flame adjustment — Horizontal reach

Set the burner in the vertical standby position. Light the burner and preheat it for at least 2 min. Move the burner into the horizontal standby position and adjust the horizontal reach of the flame to $25 \text{ mm} \pm 2 \text{ mm}$, measured as the distance from the tip of the burner stabilizer to the extreme end of the yellow part of the flame when viewed against a dark background [see Figure 3 d)].

The flame reach shall be checked before testing each set of six specimens.

NOTE If the apparatus does not have a horizontal standby position, it will be necessary to remove the test specimen before carrying out the flame adjustment.

9.1.4 Flame position

Move the burner from the standby position to the horizontal operating position (see 9.1.2). Confirm that the flame impinges on the test specimen in the correct location [see Figure 3 a)].

9.2 Procedure B (bottom edge ignition)

9.2.1 Mounting of the test specimen

Place the test specimen (see 7.1) on the pins of the test specimen holder, making certain that the pins pass through the points marked off from the template and that the back of the specimen is at least 20 mm away from the rectangular metal frame of the test specimen holder. Fit the test specimen holder to the mounting frame with the specimen vertical.

9.2.2 Operating position of the burner

Position the burner in front of, but below, the test specimen such that it lies in a plane through the vertical centreline of the test specimen and perpendicular to its surface with the longitudinal axis inclined upwards at 30° to the vertical bottom edge of the test specimen. Ensure that the distance between the tip of the burner stabilizer and the bottom edge of the test specimen is $20 \text{ mm} \pm 1 \text{ mm}$ measured as shown in Figure 3 b).

NOTE It may not be possible to obtain consistent results with fabrics that exhibit drape or sag. Surface ignition may be more appropriate for such fabrics.

9.2.3 Flame adjustment — vertical flame height

Set the burner in the vertical standby position. Light the burner and preheat it for at least 2 min. Adjust the flame height to $40 \text{ mm} \pm 2 \text{ mm}$, measured as the distance from the tip of the burner stabilizer to the extreme end of the yellow part of the flame when viewed against a dark background [see Figure 3 c)].

The flame height shall be checked before testing each set of six specimens.

9.2.4 Flame position

Move the burner from the standby position to the inclined operating position (see 9.2.2). Check that the bottom edge of the test specimen bisects the flame [see Figure 3 b)].

Dimensions in millimetres

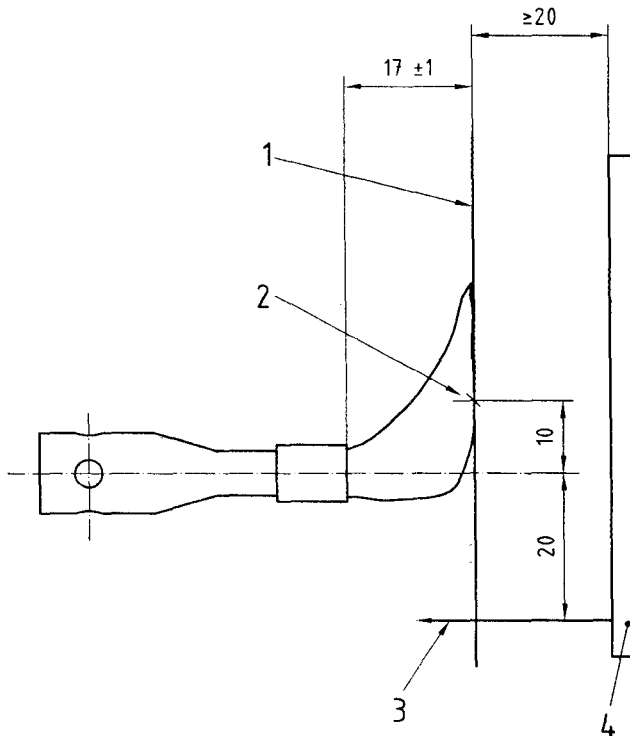

a) Surface ignition

Figure 3 — Flame position and adjustment

Dimensions in millimetres

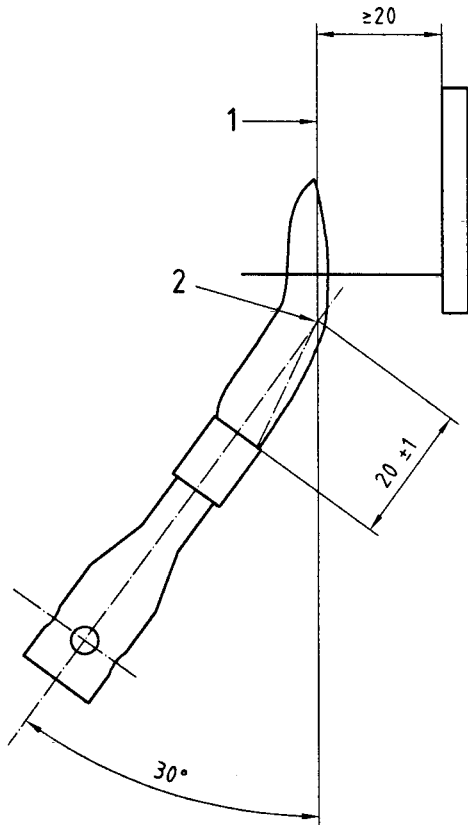

b) Bottom edge ignition

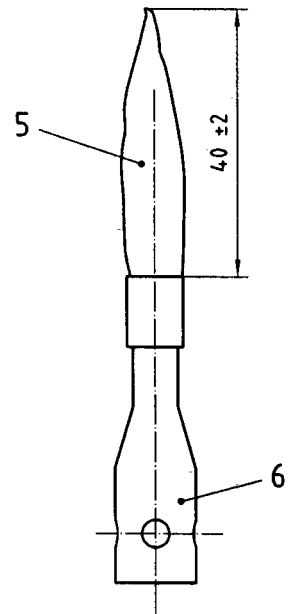

c) Vertical flame height

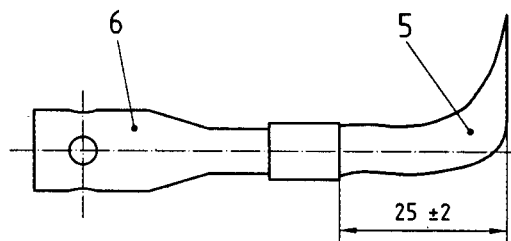

d) Horizontal reach of flame

Key

- 1 fabric specimen
- 2 nominal flame ignition point
- 3 pin
- 4 mounting frame
- 5 flame
- 6 burner

Figure 3 — Flame position and adjustment (continued)

10 Test procedure

10.1 Surface ignition

10.1.1 Set up the apparatus as described in 9.1.

10.1.2 Position a fresh test specimen in the specimen holder (see 9.1.1). Record whether the length or the width direction is vertical and which surface of the test specimen is exposed towards the test flame.

10.1.3 Apply the test flame for the flame application time that approximates to the shortest time to cause ignition.

NOTE Preliminary testing may be needed to determine this initial flame application time.

10.1.4 Record the flame application time and whether ignition has occurred.

10.1.5 Mount a fresh specimen in the same orientation in the specimen holder. If ignition has occurred with the previous specimen, apply the test flame for 1 s less; if ignition has not occurred with the previous specimen, apply the test flame for 1 s more. Record the flame application time and whether ignition has occurred.

If a specimen ignites with a 1 s flame application time, record non-ignition as "0" and retest with 1 s flame application time. If a specimen does not ignite with a 20 s flame application time, retest with a 20 s flame application time.

10.1.6 Continue testing in accordance with 10.1.5 until there are at least five instances of ignition and five instances of non-ignition. In the case of ignition at 1 s flame application time, continue until there are at least five instances of ignition at 1 s. In the case of non-ignition at 20 s flame application time, continue until there are at least five instances of non-ignition at 20 s.

NOTE The maximum flame application time used is 20 s. Materials that do not ignite with this flame application time will not normally ignite with higher flame application times. If necessary, testing can be extended above 20 s and this fact reported in the test report (see Clause 13).

10.2 Bottom edge ignition

10.2.1 Set up the apparatus as described in 9.2.

10.2.2 Position a fresh test specimen in the specimen holder (see 9.2.1). Record whether the length or the width direction is vertical and which surface of the test specimen is exposed towards the test flame.

10.2.3 Apply the test flame for a flame application time that approximates to the shortest time to cause ignition.

NOTE Preliminary testing may be needed to determine this initial flame application time.

10.2.4 Record the flame application time and whether ignition has occurred.

10.2.5 Mount a fresh specimen in the same orientation in the specimen holder. If ignition has occurred with the previous specimen, apply the test flame for 1 s less; if ignition has not occurred with the previous specimen, apply the test flame for 1 s more. Record the flame application time and whether ignition has occurred.

If a specimen ignites with a 1 s flame application time, record non-ignition as "0" and retest with 1 s flame application time. If a specimen does not ignite with a 20 s flame application time, retest with a 20 s flame application time.

10.2.6 Continue testing in accordance with 10.2.5 until there are at least five instances of ignition and five instances of non-ignition. In the case of ignition at 1 s flame application time, continue until there are at least five instances of ignition at 1 s. In the case of non-ignition at 20 s flame application time, continue until there are at least five instances of non-ignition at 20 s.

NOTE The maximum flame application time used is 20 s. Materials that do not ignite with this flame application time will not normally ignite with higher flame application times. If necessary, testing can be extended above 20 s and this fact reported in the test report (see Clause 13).

11 Calculation of the mean ignition time

Calculate the mean of the recorded times for ignition or non-ignition, whichever has occurred least. If the data relate to non-ignition, add 0,5 s; if it relates to ignition, subtract 0,5 s. Round this result to the nearest second and report as the mean ignition time for the orientation tested. See Annex B for a worked example.

12 Precision

These methods are used to determine the mean ignition time, which is the minimum flame application time required to produce sustained combustion under the specified test conditions, calculated to the nearest second. The precision of the methods is largely dependent on the type of material to be tested.

These methods are designed for use on inflammable materials, which sustain combustion when ignited. With this type of material, these methods are accurate to the nearest second. However, because the mean ignition time represents the boundary between non-ignition and ignition, both types of behaviour may be observed when the flame is applied for exactly the mean ignition time. See worked example in Annex B.

The methods are not suitable for flame-retardant materials, which give only very limited combustion rather than sustained combustion. The limited combustion of these materials is difficult to detect by these methods and flame-retardant materials are consistently recorded as "not ignited by 20 s". The flame-retardant properties of these fabrics may be determined by other test methods.

Certain intermediate materials give extremely variable results. These materials give sustained combustion only under certain limited circumstances, i.e., sustained combustion is only achieved within a narrow range of flame application times. This inconsistent behaviour is a property of the material and not a feature of the test methods.

13 Test report

The test report shall include the following information:

- a) a statement that the test was carried out in accordance with this International Standard and details of any deviation from it;
- b) gas used;
- c) date of test;
- d) ambient conditions of temperature and relative humidity in the area in which the test was carried out (see 8.2);
- e) technique used to attach fabrics that cannot be supported on pins (see 7.2);
- f) identification of fabric tested including details of any pretreatment, e.g. a cleansing procedure;
- g) which surface was exposed towards the flame, which fabric direction was vertical, and whether surface or bottom ignition was used;
- h) a table giving the flame application time and the observation of ignition or non-ignition for each test specimen;
- i) the mean ignition time calculated in accordance with Clause 11 for each orientation tested;
- j) if the fabric did not ignite with a 20 s flame ignition time (or higher maximum flame ignition time: see Notes to 10.1.6 and to 10.2.6).

Annex A (normative)

Description and construction of the burner

A.1 Description

The burner provides a flame of suitable dimensions, the length of which can be adjusted from 10 mm to 60 mm.

A.2 Construction

The construction of the burner is shown in Figure 1 a). The burner consists of three parts.

a) Gas jet

The orifice diameter of the gas jet [see Figure 1 b)] shall be $0,19 \text{ mm} \pm 0,02 \text{ mm}$.

The orifice shall be drilled and, after drilling, all burrs shall be removed from both ends of the drilled hole without rounding the corners.

b) Burner tube

The burner tube [see Figure 1 d)] consists of four zones:

- 1) air chamber;
- 2) gas mixing zone;
- 3) diffusion zone;
- 4) gas outlet.

Within the air chamber, the burner tube has four air holes 4 mm in diameter for air inlets. The forward edge of the air holes is approximately level with the tip of the jet.

The diffusion zone is of conical shape and has the dimensions indicated in Figure 1 d). The burner has a bore of 1,7 mm inside diameter and outlet of 3,0 mm inside diameter.

c) Flame stabilizer

The flame stabilizer is as detailed in Figure 1 c). Details of the availability of the specified burner may be obtained from the Secretariat of ISO/TC38/SC19.

Annex B (informative)

Calculation of mean ignition time — worked example

B.1 Test results

The results of twelve tests in one orientation are given in Table B.1. In recording the results, a cross (X) has been used to indicate ignition and a zero (0) to indicate non-ignition.

Table B.1 — Test results

Test number	Flame application time s	Result	Test number	Flame application time s	Result
1	6	X	7	4	0
2	5	X	8	5	X
3	4	X	9	4	X
4	3	0	10	3	0
5	4	0	11	4	X
6	5	X	12	3	0

B.2 Calculations

Based on the test results, Table B.2 was prepared to summarize the cases of ignition and non-ignition occurring at each flame application time.

Table B.2 — Summary of results

Flame application time s	Number of cases of ignition	Number of cases of non-ignition
6	1	0
5	3	0
4	3	2
3	0	3

Table B.2 indicates that non-ignition occurred least (i.e. there were seven cases of ignition and five cases of non-ignition). Therefore the mean of the recorded times at which non-ignition occurred is calculated as follows:

$$\frac{(2 \times 4) + (3 \times 3)}{5} = 3,4 \text{ s}$$

The mean ignition time (mean of the recorded non-ignition times plus 0,5 s) is $3,4 + 0,5 = 3,9 \text{ s}$. Rounded to the nearest second, the mean ignition time is 4 s.

NOTE If ignition occurs least, the mean of the recorded times at which ignition occurs is calculated. 0,5 s is subtracted from the value obtained, and the resulting value, rounded to the nearest second, is reported as the mean ignition time.

Annex C (informative)

Experimental techniques

The quality of the experimental technique required will depend to a significant extent on the design of the equipment used; e.g., the less automatic the equipment, the greater will be the need for a skilled operator in order to obtain high precision.

Some practical points of a general nature are as follows.

- a) For reason of safety, the test equipment should be remote from the gas cylinder, which could be located outside the building. In this case, a manually-operated shut-off valve should be installed where the piping enters, inside the room housing the apparatus. On each occasion the equipment is used, time should be allowed for pure gas to reach the burner jet and provide a steady flame.
- b) The equipment should be installed and used so that it is not possible for smouldering particles, which may be carried away by the hot gases or may fall from the specimen, to come to rest on combustible materials. Protective clothing, fire extinguishers and alarm signals should be available to the operator.
- c) It is important to keep the apparatus clean in order to maintain safety.
- d) Some unfinished fabrics, such as single knit jersey knitted fabrics, are liable to curl. This tendency may be reduced by subsequent processing. It is desirable to test this type of fabric in its finished state.
- e) Residual material adhering to the pins after testing may be removed by scraping with a wire brush. Any smouldering material must be extinguished before placing it with other waste in a non-combustible container.
- f) Preliminary tests should be undertaken to establish if one surface of the fabric under examination is likely to produce different inflammability behaviour from the other. If they are different, both surfaces should be tested.

NATIONAL ANNEX A
(*National Foreword*)

The conditioning temperature of $20\pm 2^{\circ}\text{C}$ as specified in International Standard is not suitable for tropical countries like India where the atmospheric temperature is normally much higher than 20°C . It is almost impossible to maintain this temperature specially during summer when the atmospheric temperature rises even up to 50°C . In view of the above, Indian Standard IS 6359 : 1971 'Method for conditioning of textiles' which specifies a temperature of $27\pm 2^{\circ}\text{C}$ for conditioning of the test specimens for the tropical countries like India shall be followed.

Bureau of Indian Standards

BIS is a statutory institution established under the *Bureau of Indian Standards Act, 1986* to promote harmonious development of the activities of standardization, marking and quality certification of goods and attending to connected matters in the country.

Copyright

BIS has the copyright of all its publications. No part of these publications may be reproduced in any form without the prior permission in writing of BIS. This does not preclude the free use, in the course of implementing the standard, of necessary details, such as symbols and sizes, type or grade designations. Enquiries relating to copyright be addressed to the Director (Publications), BIS.

Review of Indian Standards

Amendments are issued to standards as the need arises on the basis of comments. Standards are also reviewed periodically; a standard along with amendments is reaffirmed when such review indicates that no changes are needed; if the review indicates that changes are needed, it is taken up for revision. Users of Indian Standards should ascertain that they are in possession of the latest amendments or edition by referring to the latest issue of 'BIS Catalogue' and 'Standards: Monthly Additions'.

This Indian Standard has been developed from Doc: No. TX 05 (0757).

Amendments Issued Since Publication

Amend No.	Date of Issue	Text Affected

BUREAU OF INDIAN STANDARDS

Headquarters:

Manak Bhavan, 9 Bahadur Shah Zafar Marg, New Delhi 110002

Telephones: 2323 0131, 2323 3375, 2323 9402

website : www.bis.org.in

Regional Offices:

	Telephones
Central : Manak Bhavan, 9 Bahadur Shah Zafar Marg NEW DELHI 110002	{ 2323 7617 2323 3841
Eastern : 1/14 C.I.T. Scheme VII M, V.I.P. Road, Kankurgachi KOLKATA 700054	{ 2337 8499, 2337 8561 2337 8626, 2337 9120
Northern : SCO 335-336, Sector 34-A, CHANDIGARH 160022	{ 260 3843 260 9285
Southern : C.I.T. Campus, IV Cross Road, CHENNAI 600113	{ 2254 1216, 2254 1442 2254 2519, 2254 2315
Western : Manakalaya, E9 MIDC, Marol, Andheri (East) MUMBAI 400093	{ 2832 9295, 2832 7858 2832 7891, 2832 7892

Branches: AHMEDABAD. BANGALORE. BHOPAL. BHUBANESHWAR. COIMBATORE. FARIDABAD. GHAZIABAD. GUWAHATI. HYDERABAD. JAIPUR. KANPUR. LUCKNOW. NAGPUR. NALAGARH. PATNA. PUNE. RAJKOT. THIRUVANANTHAPURAM. VISAKHAPATNAM.